

Slicer 305

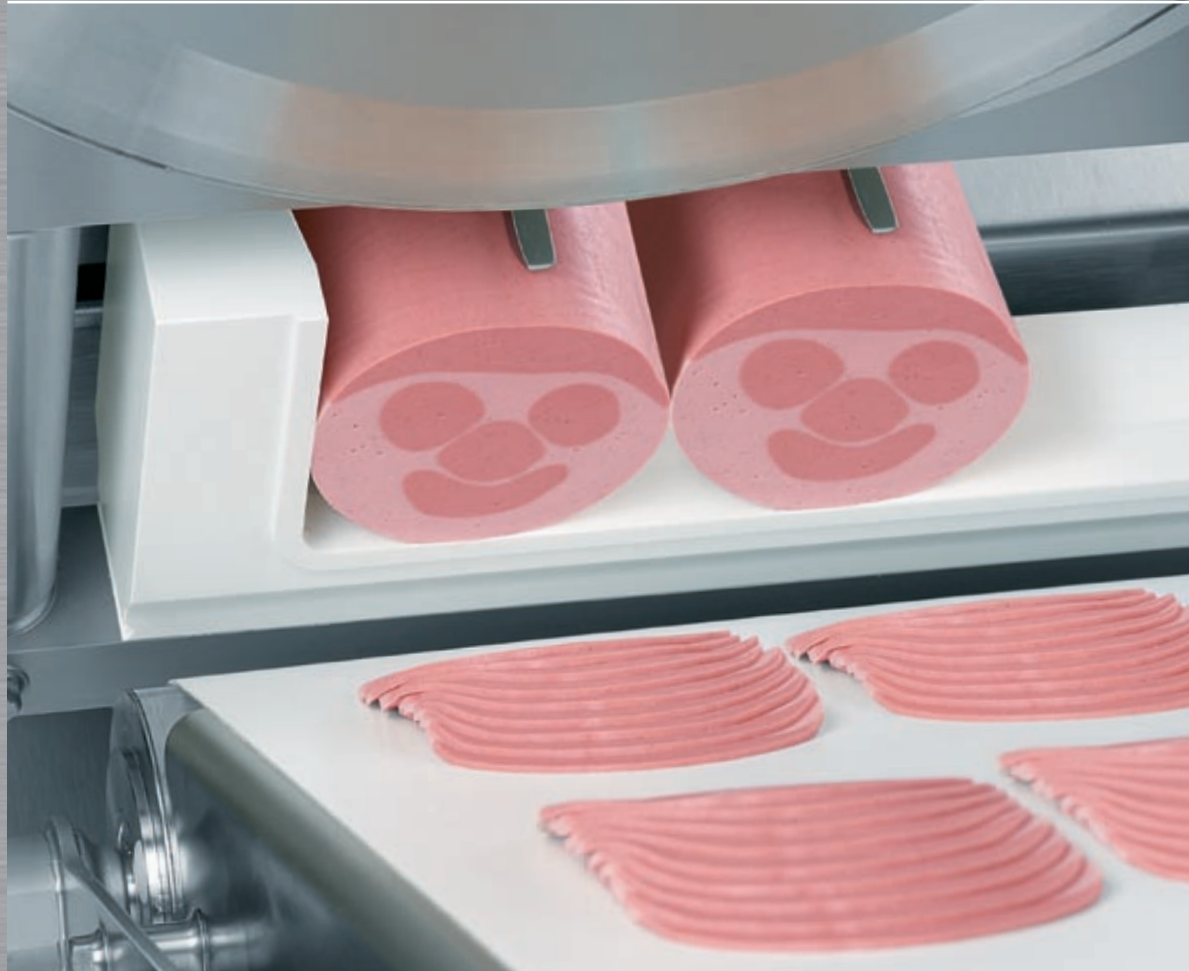

The powerful compact Slicer.

weber[®]
The High Tech Company

Weber Slicer 305

The powerful compact Slicer.

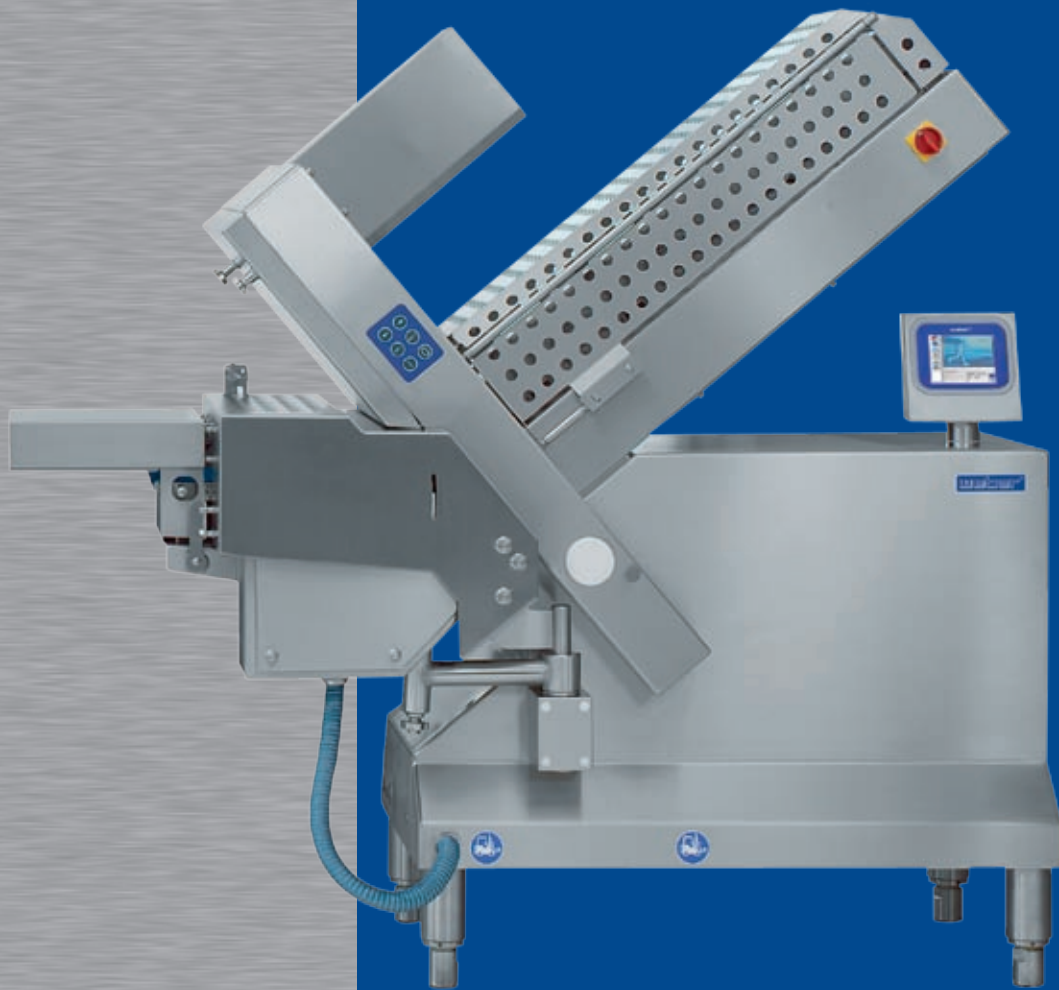

- Upgrade older equipment to state-of-the-art slicing technology and hygiene
- Slice 3 or 4 logs simultaneously through the 250 mm wide throat
- Slice at blade speeds up to 400 RPM
- Easy to operate – user friendly
- Programmable touch screen assures rapid product changeovers
- Six popular presentation styles, including ultra-thin shaved at 0.1 mm
- Options available including interleaver, checkweigher and stack lowering for stacks up to 80 mm.

Slicer 305 CCS UB

In the basic UB version, the Slicer 305 is equipped with a universal conveyor that requires little space while achieving a high degree of productivity.

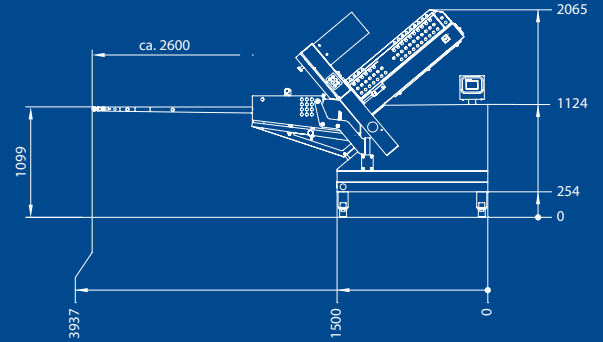

Slicer 305 CCL

Economically automated: Slicer 305 with transport conveyors from 2600 to 5100 mm in length. The conveyor speed is controlled automatically. Can be upgraded to MLC or SLC.

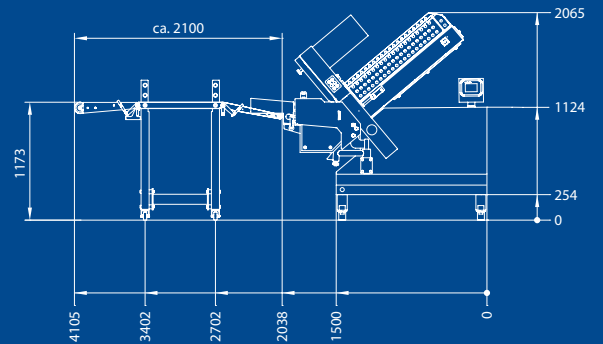

Slicer 305 MLC

Labor-saving technology: Slicer 305 with checkweigher and marking unit. Any off-weight portion will automatically be offset on the transport conveyor for manual operator correction.

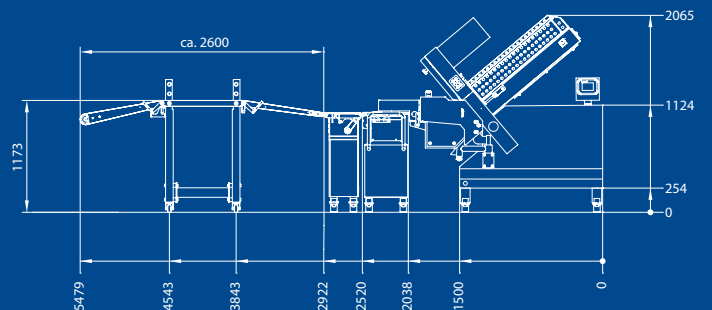

Slicer 305 SLC

Everything under control: Slicer 305 as a complete processing line with checkweigher, rocker, reject conveyor and transport conveyor. Portions that are not within specified weight limits are detected by the checkweigher, guided by the rocker onto the reject conveyor and corrected there by hand.

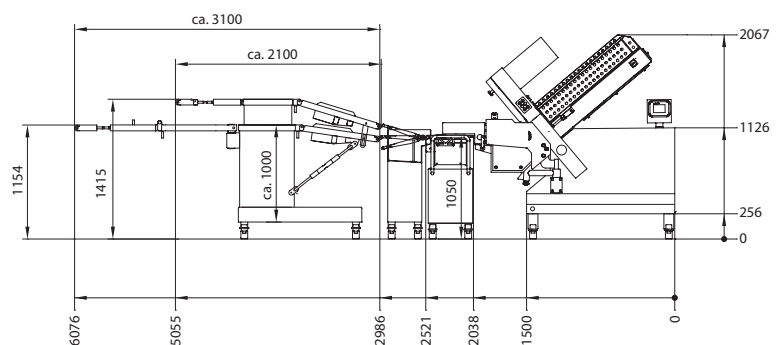

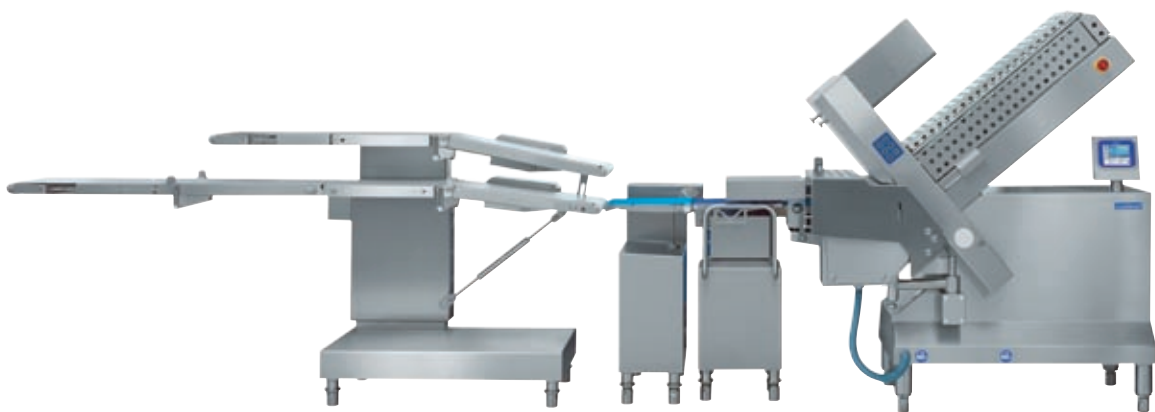
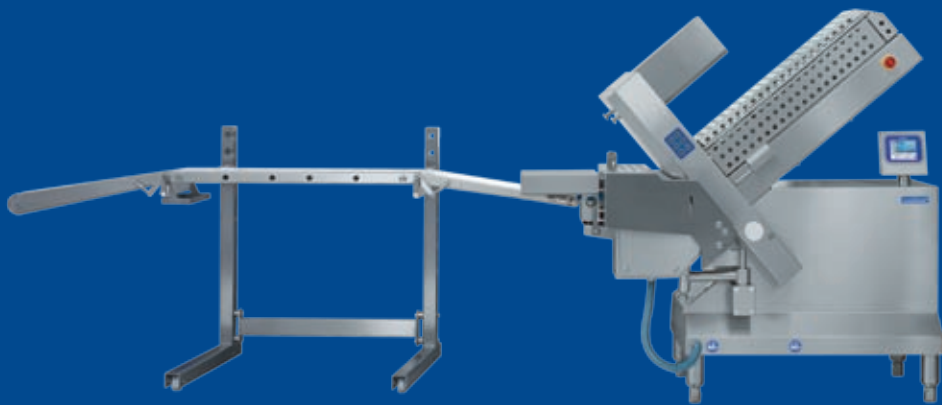
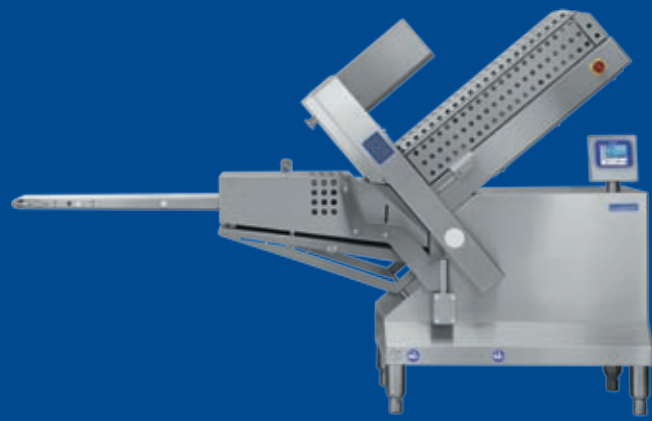

Great flexibility. Perfect presentations.

Increase sales with these attractive, appetizing presentations.

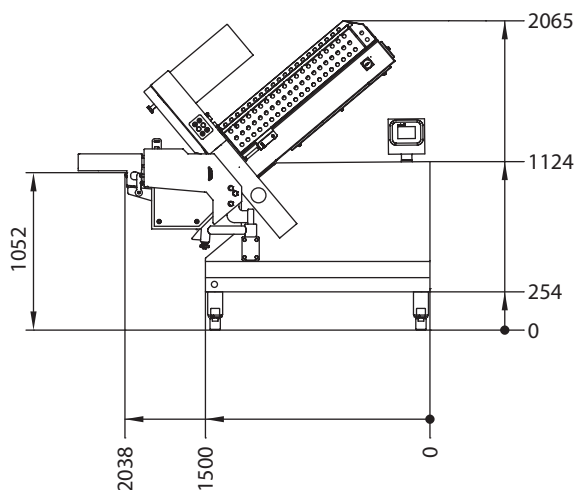
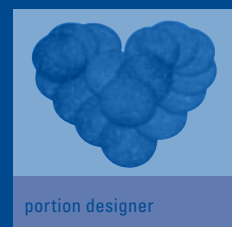
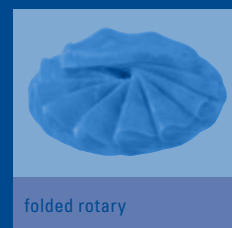
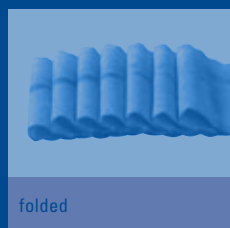
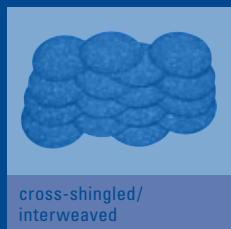
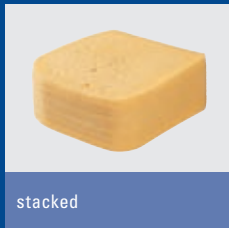

Technical data

Slicing throat (w x h mm):	250 x 135 max., 230 x 150 optional
Product length mm:	800 max.
Cutting system:	circular knife
Max. cutting speed (rpm):	400
Cutting thickness (mm):	0.1 – 50

**Call today. We will be pleased to
provide you with complete information.**

Weber Maschinenbau GmbH

Breidenbach

Günther-Weber-Straße 3
35236 Breidenbach
Germany
Fon: +49 6465 918-0
Fax: +49 6465 918-100
info@weberweb.com
www.weberweb.com

Weber Maschinenbau GmbH

Neubrandenburg

Feldmark 11
17034 Neubrandenburg
Germany

Betriebsstätte Groß Nemerow

Schwarzer Weg 5
17094 Groß Nemerow
Germany

Fon: +49 395 4506-0
Fax: +49 395 4506-110
info@weberweb.com

Weber, Inc.

10701 N. Ambassador Drive
Kansas City, MO 64153
USA
Fon: +1 816 8910072
Fax: +1 816 8910074
usasales@weberslicer.com
www.weberslicer.com

Weber France SAS

61, Chemin de la Chapelle Saint Antoine
95300 Ennery
France
Fon: +33 1 30 303465
Fax: +33 1 30 303625
weber.france@weberweb.com

Weber Benelux B.V.

Bgm. Schalijlaan 26
2908 LS Capelle a/d IJssel
Netherlands
Fon: +31 10264 0100
Fax: +31 10451 0592
info@weberweb.com

Weber Poland Sp. z o.o.

ul. Łączyny 3
02-820 Warszawa
Poland
Fon: +48 22 4623273-74
Fax: +48 22 4623277-78
pl@weberweb.com

Weber CZ s.r.o.

Tuřanka 115
627 00 Brno
Czech Republic
Fon: +420 532123370
Fax: +420 532123371
cz@weberweb.com

Weber Maschinenbau S. R. L.

Calea Turzii nr. 7, etaj 3, ap. 2
400193 Cluj-Napoca
Romania
ro@weberweb.com

weber[®]

The High Tech Company