

Slicer 604

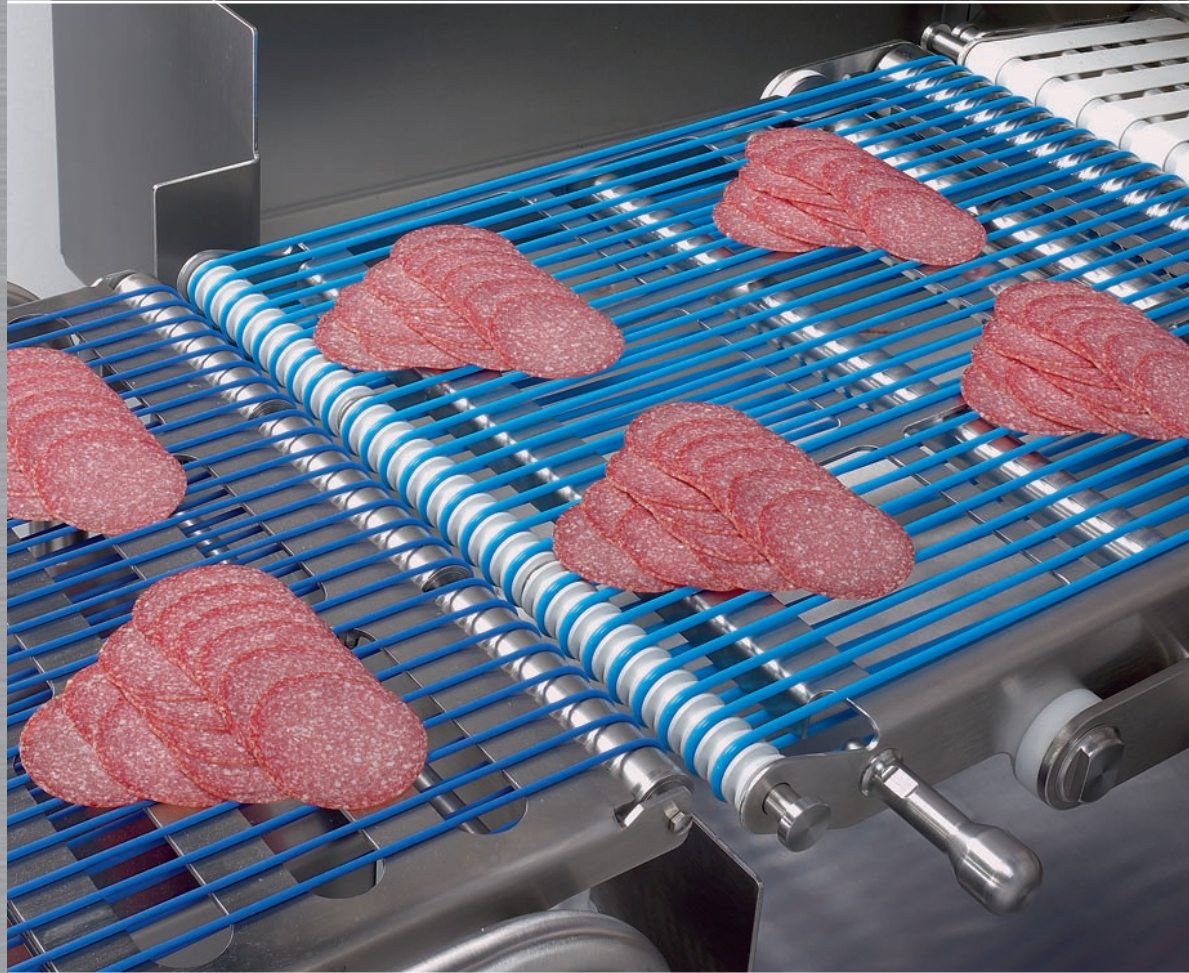

High performance and flexibility.

weber[®]
The High Tech Company

Weber Slicer 604

The all-rounder with circular blade cutting technology.

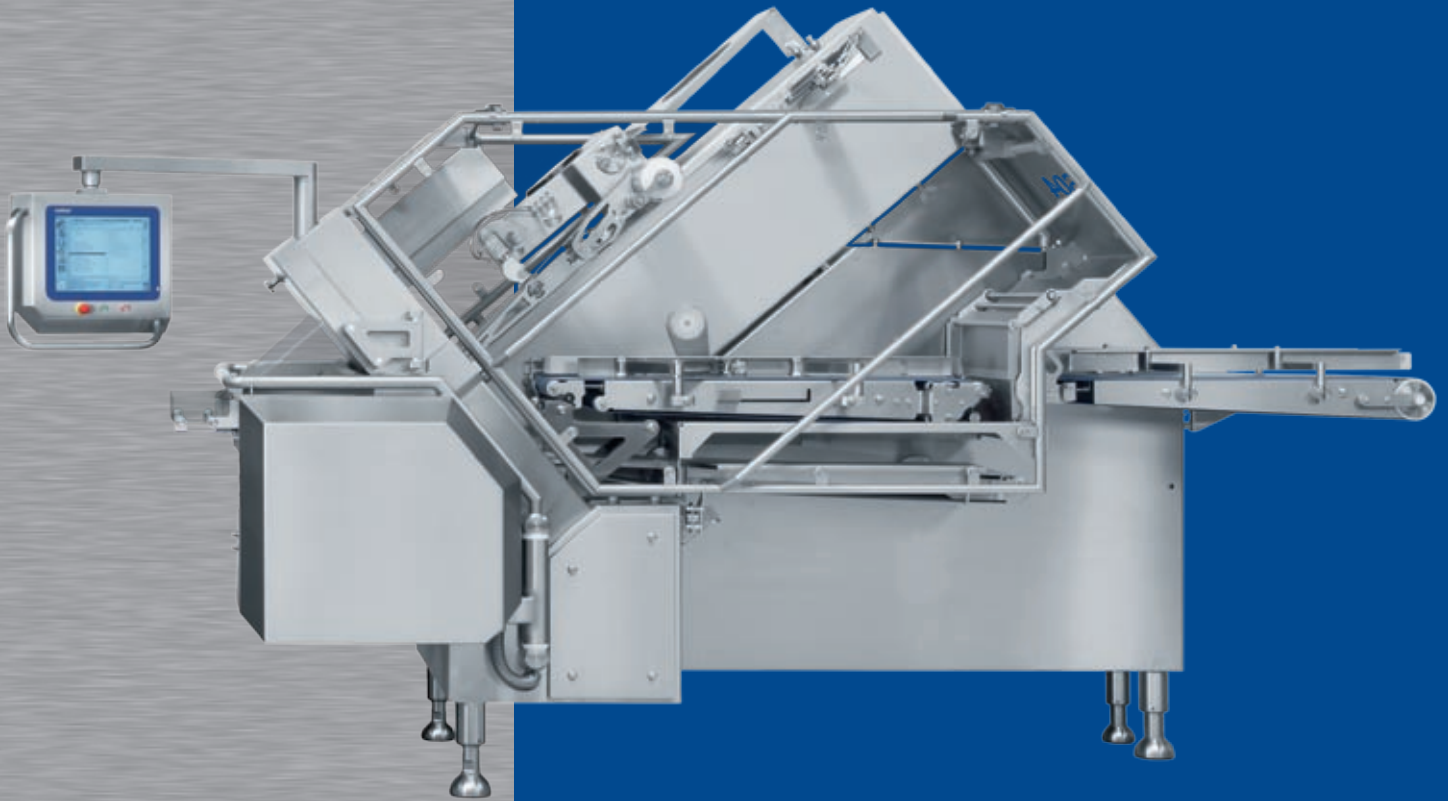

- Quick product changeover due to automatic central loading
- Optimum slice quality even with difficult products
- Easily and accurately adjust slicing throat height and width
- Circular blade create perfect slices at speed up to 600 RPM
- Wide range of options available (e.g. interleaver, automatic infeder, turntable, checkweigher and Food Robotics)
- Carrier unit for max. product length of 1200 mm
- The following presentation forms are possible (depending on configuration):
shingles – straight or interweaved, stacks, staggered stack, shaved meat, slice folding, round and oval, pieces up to 50 mm

Slicer 604 CCL

Economically automated: Slicer 604 with transport conveyors from 2600 to 5100 mm in length. The conveyor speed is controlled automatically. Can be retrofitted to MLC or SLC.

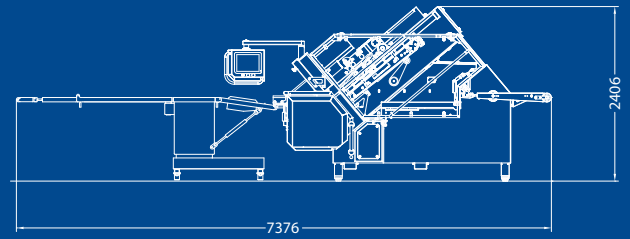

Slicer 604 SLC

High product yield: Slicer 604 with checkweigher, rocker, reject conveyor and transport conveyor. Portions that are not within the weight limits are detected by the weigher, guided onto the reject conveyor by the rocker and corrected there by hand.

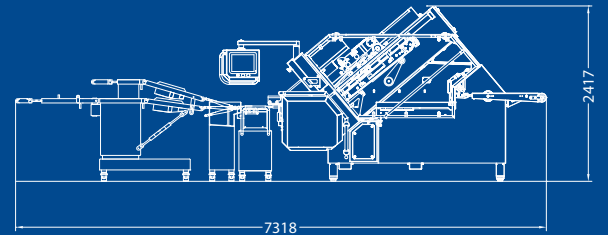

Slicer 604 MCS

Industrial slicing to perfection: Slicer 604 in fully automatic mode including checkweigher, rocker, reject conveyor and infeed unit (line divider, grouping conveyor and buffer conveyor). This configuration enables automatic delivery of portions to the packaging machine in the desired format.

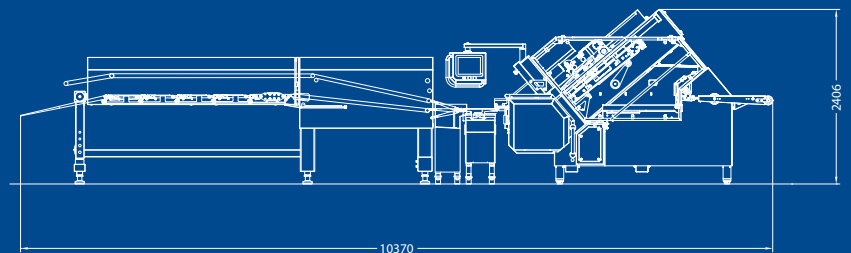

Slicer 604 RCS WFR

Versatile and powerful: In one processing line with checkweigher, rocker and robot loader, as well as the Weber food robot, the Slicer 604 is the perfect system for performing demanding tasks. The WFR precisely feeds the cut and portioned products into packaging.

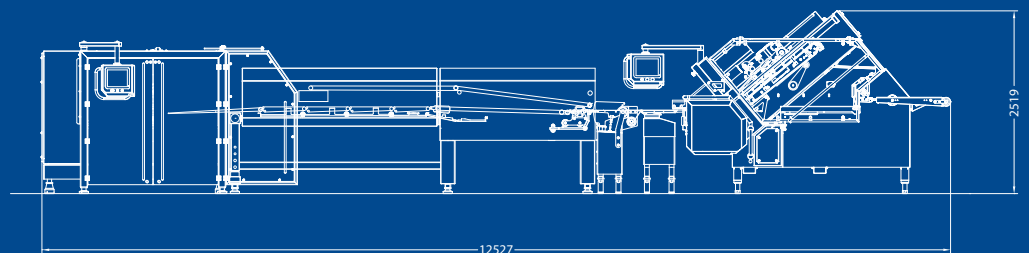

Slicer 604 RCS WPR

Individual and powerful: In one processing line with checkweigher, feeding buffering system and the Weber Pick Robot, the 604 provides the ultimate in flexibility and hygienic design. Sliced portions are fed into almost any packaging machine according to individual customer requirements. Feeding programs can be changed at the touch of a button

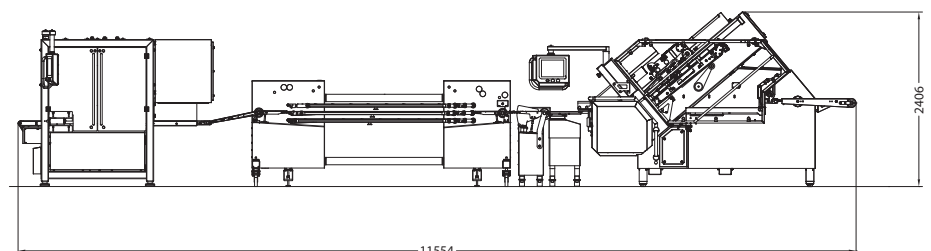

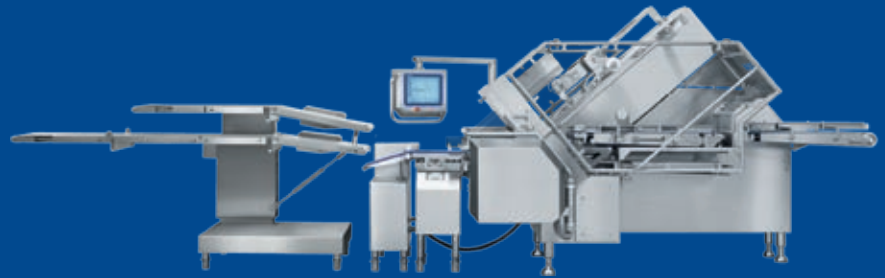

Great flexibility. Perfect presentations.

Increase sales with these attractive, appetizing presentations.

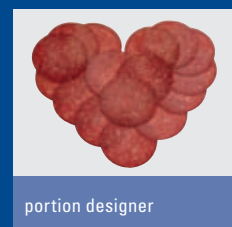
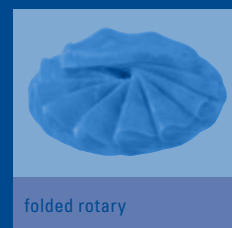
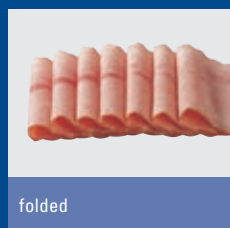
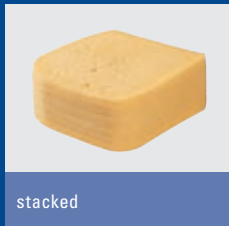

*Application only available in combination with Portion-Designer CCU.

Technical data

Slicing throat (w x h mm):	380 x 125 –165
Product length (mm):	1200 (optional: 1600)
Cutting system:	circular blade
Max. cutting speed (rpm):	600
Cutting thickness (mm):	0.1 – 50

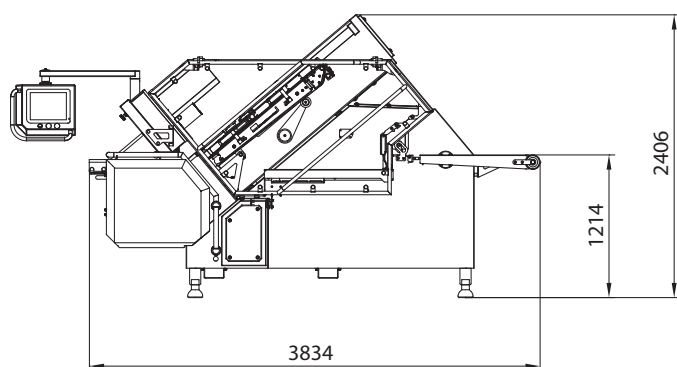

**Call today. We will be pleased to
provide you with complete information.**

**Weber Maschinenbau GmbH
Breidenbach**

Günther-Weber-Straße 3
35236 Breidenbach
Germany
Fon: +49 6465 918-0
Fax: +49 6465 918-100
info@weberweb.com
www.weberweb.com

**Weber Maschinenbau GmbH
Neubrandenburg**

Feldmark 11
17034 Neubrandenburg
Germany

Betriebsstätte Groß Nemerow
Schwarzer Weg 5
17094 Groß Nemerow
Germany

Fon: +49 395 4506-0
Fax: +49 395 4506-110
info@weberweb.com

Weber, Inc.

10701 N. Ambassador Drive
Kansas City, MO 64153
USA
Fon: +1 816 8910072
Fax: +1 816 8910074
usasales@weberslicer.com
www.weberslicer.com

Weber France SAS

61, Chemin de la Chapelle Saint Antoine
95300 Ennery
France
Fon: +33 1 30 303465
Fax: +33 1 30 303625
weber.france@weberweb.com

Weber Benelux B.V.

Bgm. Schalijslaan 26
2908 LS Capelle a/d IJssel
Netherlands
Fon: +31 10264 0100
Fax: +31 10451 0592
info@weberweb.com

Weber Poland Sp. z o.o.

ul. Łączyny 3
02-820 Warszawa
Poland
Fon: +48 22 4623273-74
Fax: +48 22 4623277-78
pl@weberweb.com

Weber CZ s.r.o.

Tuřanka 115
627 00 Brno
Czech Republic
Fon: +420 532123370
Fax: +420 532123371
cz@weberweb.com

Weber Maschinenbau S. R. L.

Calea Turzii nr. 7, etaj 3, ap. 2
400193 Cluj-Napoca
Romania
ro@weberweb.com