



JO-BEX-MAN

PROJECT:

**ERGONOMIC HAM DEMOLDER
+ MOLDS ELEVATION TABLE**

AGENT:

ERGONOMIC DEMOLDING SYSTEM:

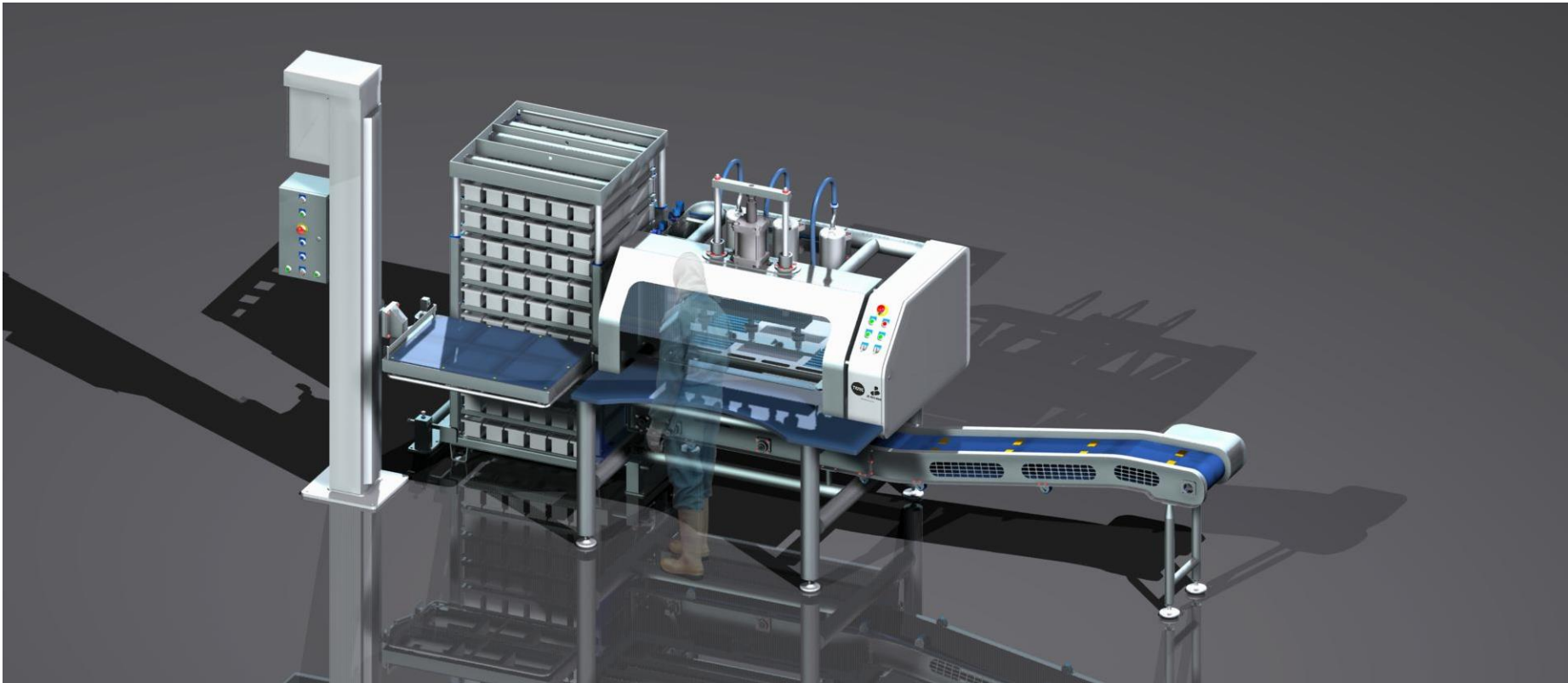

MAIN PARTS FRONT:

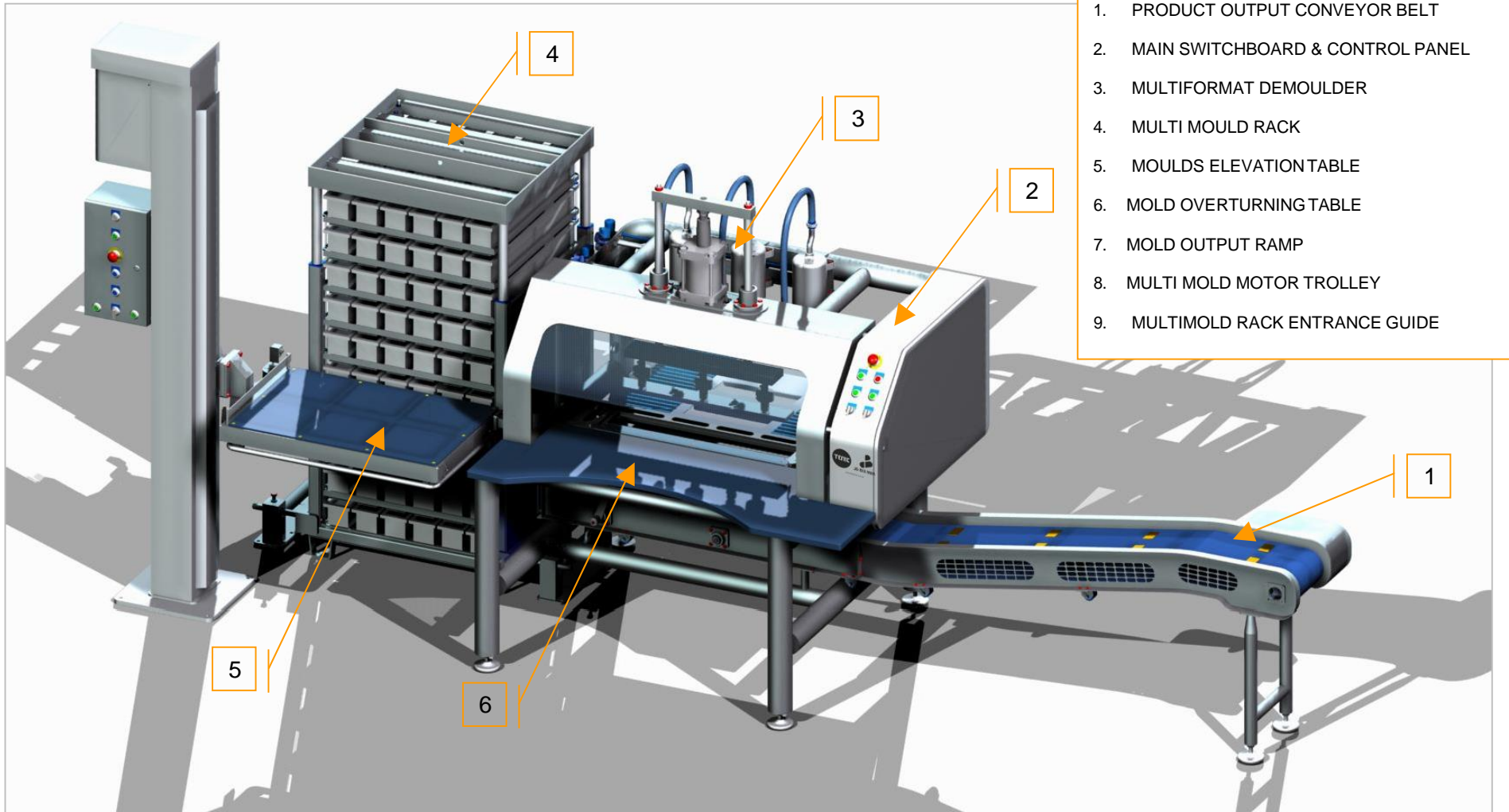

1. PRODUCT OUTPUT CONVEYOR BELT
2. MAIN SWITCHBOARD & CONTROL PANEL
3. MULTIFORMAT DEMOULDER
4. MULTI MOULD RACK
5. MOULDS ELEVATION TABLE
6. MOLD OVERTURNING TABLE
7. MOLD OUTPUT RAMP
8. MULTI MOLD MOTOR TROLLEY
9. MULTIMOLD RACK ENTRANCE GUIDE

MAIN PARTS BACK:

- 7. MOLD OUTPUT RAMP
- 8. MULTI MOLD MOTOR TROLLEY
- 9. MULTIMOLD RACK ENTRANCE GUIDE

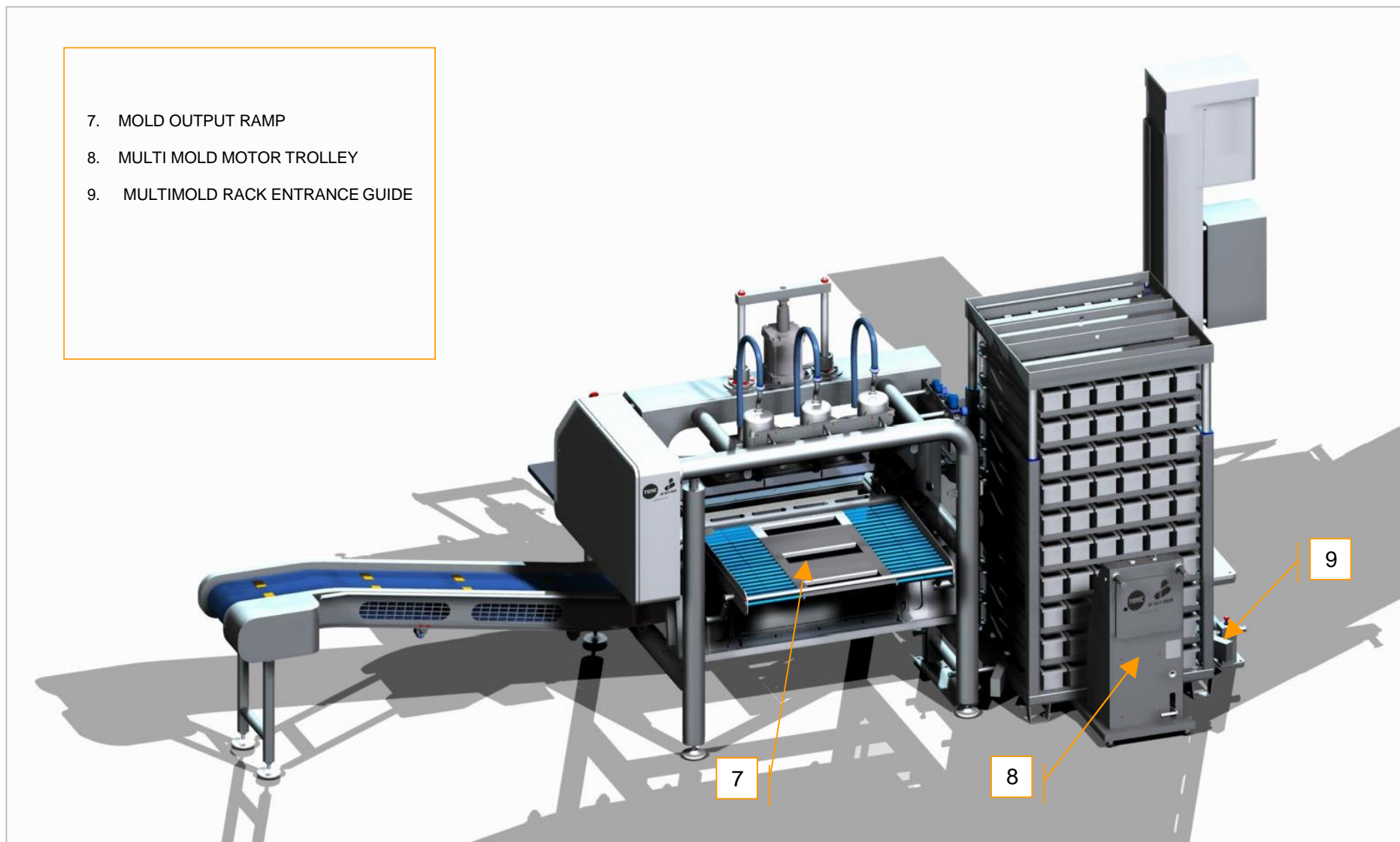

FLOWS FRONT:

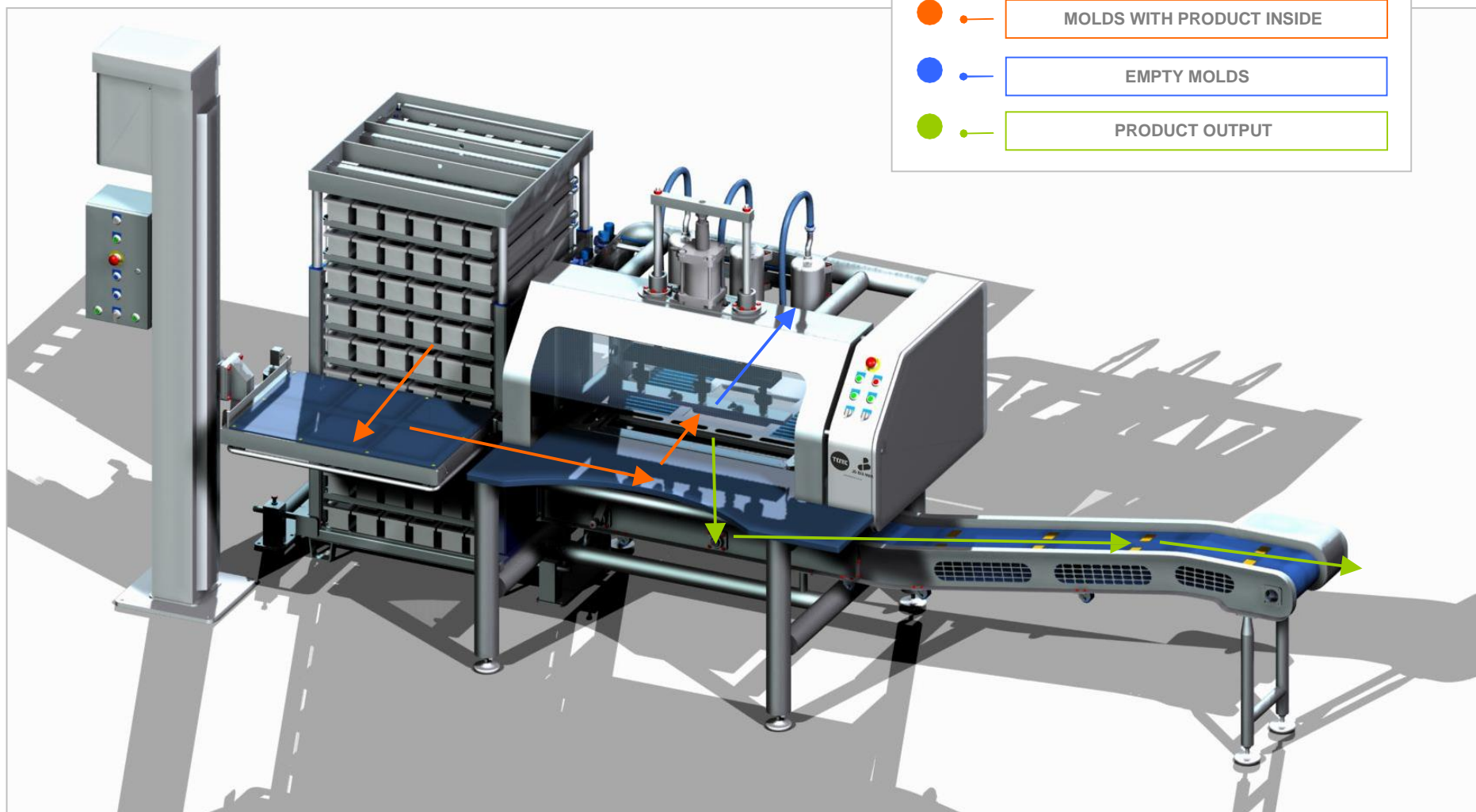

FLows BACK:

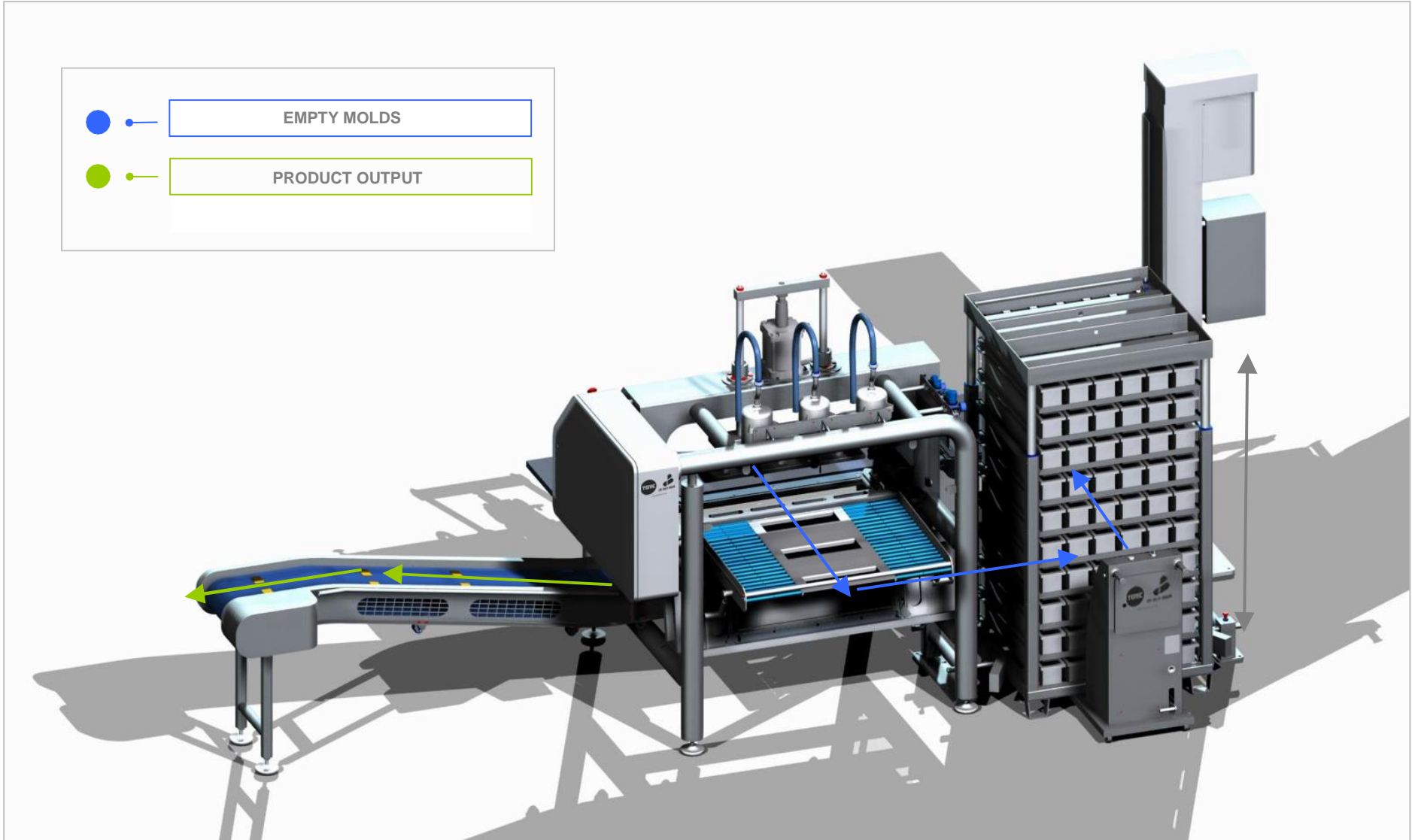
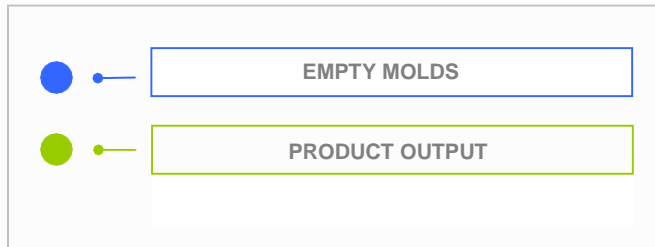



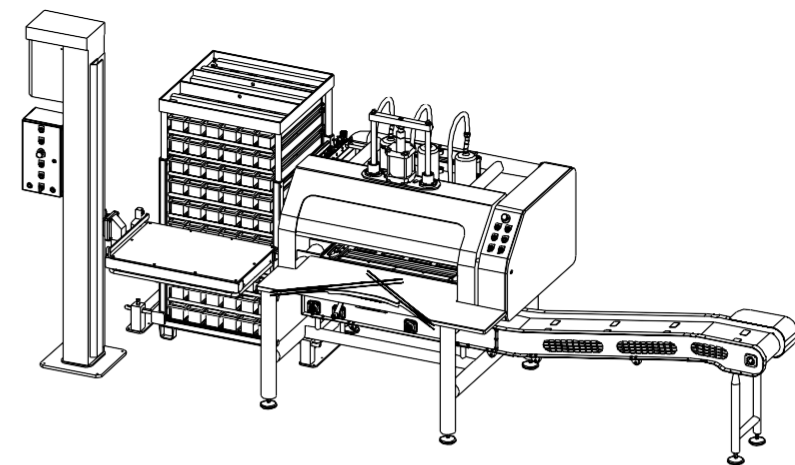
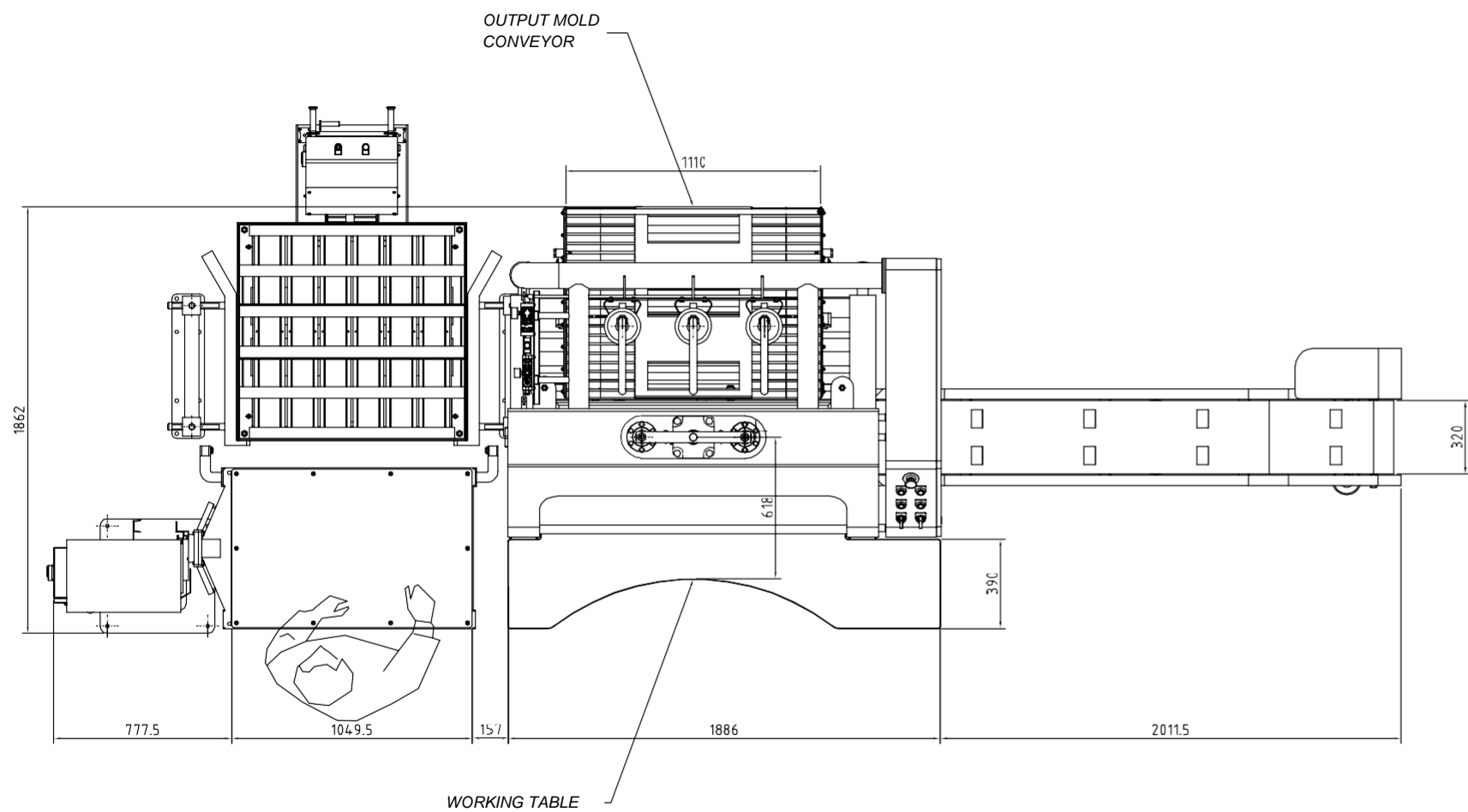
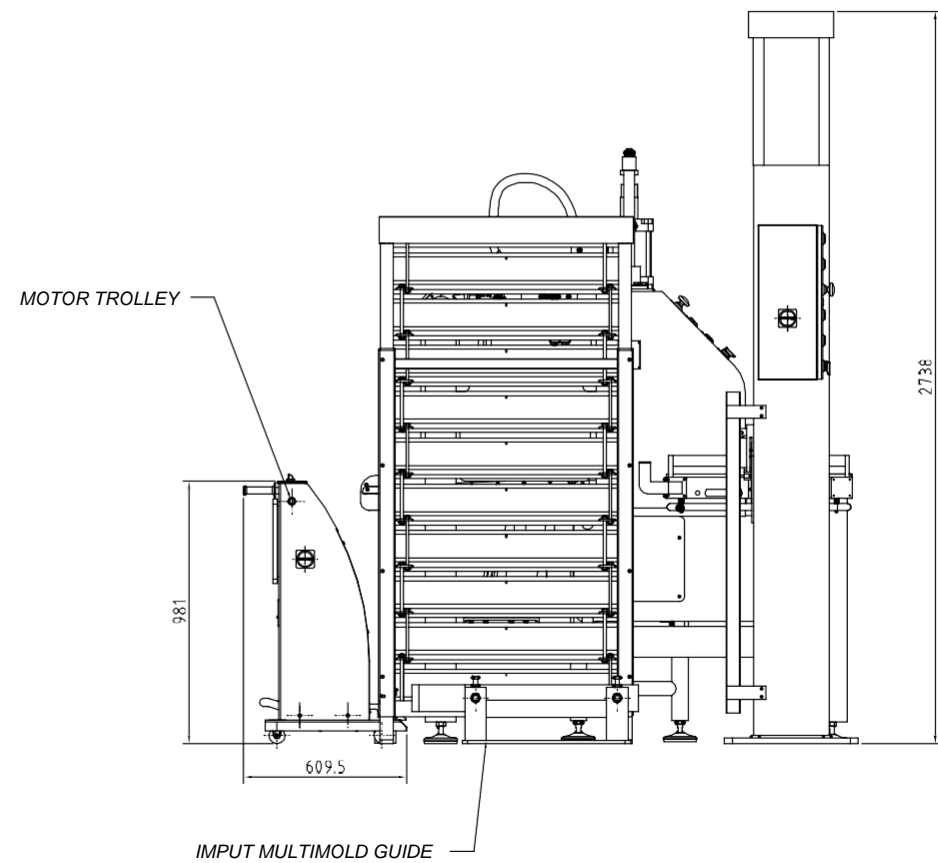
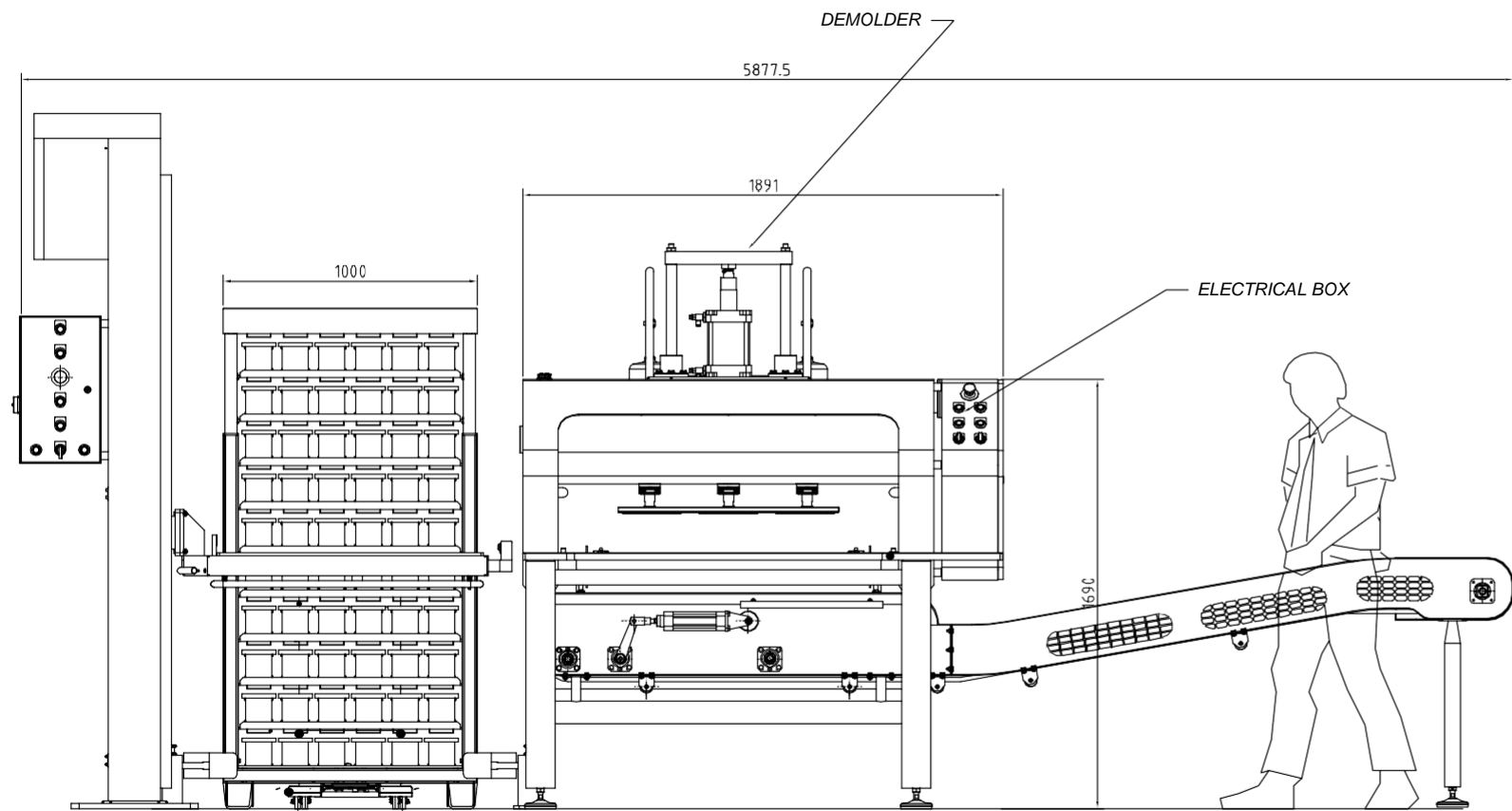

| | | | | | |
|-------------|--|--------------|---------------|-------------------|------|
| T | | AISI 304 | | | |
| Fabricación | Pezas máquina | Material | Observaciones | Metros | Peso |
| | Fecha | Nombre | | | |
| Dibujado | 05/06/2013 | ANTONI PAGÉS | | | |
| Modificado | | | | | |
| Escala | Conjunta | | Nº de Plano : | | |
| | 1/20 | | | 06 494 01 | |
| Proyecto | DESMOLDEADOR MANUAL + PLATAFORMA ELEVADORA | | | Substituye a : | |
| | | | | Substituido por : | |





C/ Del Ter, 4-6 · Poligon Industrial Sau 5 · 17165 La Celler de Ter · (Girona) Spain
Tel.(+34) 972 221 715 / Fax (+34) 972 221 875 / info@jobexman.com
www.jobexman.com